

# Conductivity/Resistivity

**THORNTON**

Leading Pure Water Analytics

- Two channels of conductivity/resistivity
- Calibration with NIST traceability
- Accurate three-wire temperature measurement



## 200CR Two-Channel Conductivity/Resistivity Measurement System

**METTLER TOLEDO**

## Benefits

- Single instrument for wide range of measurement with appropriate two-electrode sensors
- Easy operation with text-based menus
- One instrument model for:
  - Conductivity
  - Resistivity
  - Temperature
  - Total Dissolved Solids (ppm/ppb)
  - % Rejection
  - Difference
  - Ratio
  - % Chemical Concentration for HCl, H<sub>2</sub>SO<sub>4</sub>, NaOH

Each channel can be set to measure two of the parameters listed, for a total of four different measurements. With a wide choice of displayed information, the Thornton 200CR instrument sets the standard for flexibility and value in its class.

The instrument's dual input option allows all combinations of 0.1 cm<sup>-1</sup> and 10 cm<sup>-1</sup> conductivity sensors to be used together. Only a single channel may be used with a 50 cm<sup>-1</sup> sensor, unless sensor locations are electrically isolated from each other.

## Applications

**Pure water treatment** for ultrapure semiconductor rinsing, critical power/steam makeup and pharmaceutical waters requires accurate, reliable monitoring of purification steps as well as the final product quality. The 200CR provides efficient two-channel monitoring of reverse osmosis (with % rejection computation), deionization and distillation stages, assuring in-spec operation throughout the system.

**Semiconductor processing** in rinsers and wet benches relies on precise resistivity alarming at ultrapure 18 Mohm-cm levels. Highest measurement accuracy and world-recognized Thornton-Light temperature compensation assure consistent water and product quality.

**Power plant cycle chemistry** monitoring requires specialized temperature compensation for cation conductivity and ammonia/amine treated specific conductivity measurements. Thornton's sophisticated compensation algorithms have proven themselves superior by a wide margin, fully accounting for the changing ionization of water as it is affected by acidic cation conductivity samples or alkaline treatment chemicals.

**Pharmaceutical water monitoring** to meet USP <645> requires accurate, validated, non-temperature compensated conductivity measurement plus the temperature value. Compensated values can also be displayed with the 200CR. In addition, temperature and uncompensated conductivity values are compared against the internal USP <645> Stage 1 table of limits with user selectable safety margins, and the 200CR signals an alarm if the margin is exceeded.

## Functional

Ranges:	
Conductivity	0.002 $\mu\text{S/cm}$ to 1000 $\text{mS/cm}$
Resistivity	1.0 $\Omega\text{-cm}$ to 500 $\text{M}\Omega\text{-cm}$
TDS	(ppm/ppb) covers equivalent conductivity range
Concentration	0-15% HCl, 0-20% $\text{H}_2\text{SO}_4$ , 0-15% NaOH, by weight
Temperature	-40 to 200 $^\circ\text{C}$ (-40 to 392 $^\circ\text{F}$ )
Resolution:	0.001 $\mu\text{S/cm}$ , 0.001 $\text{M}\Omega\text{-cm}$ , 0.01 $^\circ\text{C}$
Sensor Inputs:	From Thornton conductivity sensors with Pt1000 RTD, via accessory patch cord.
Temperature Compensation:	Automatic, referenced to 25 $^\circ\text{C}$ for resistivity, conductivity, % rejection and TDS. Field selectable for standard high purity (Thornton/Light), cation/ammonia/ETA (power industry), or 75% isopropyl alcohol. Non-temperature compensated measurement is also standard, to meet USP <645> requirements. Concentration measurements also include specialized compensation for the specific material.

## Outputs

Setpoints/Alarms:	Four controlled setpoints can be set as high or low limits (or USP <645> limit for conductivity). Any relay can be activated by multiple setpoints.
Relays:	Standard: 2 mechanical SPDT, 5 amp at 250 VAC or 30 VDC resistive load; Optional, additional: 2 AC-only, solid state, SPST, 1.5 amp, 250 VAC resistive load, 10 mA minimum. All relays are potential-free and have individually adjustable delay and hysteresis (deadband).
Analog output Signals:	Two optional powered 4-20 mA outputs (recalibratable to 0-20 mA), 500 ohm load maximum, freely scalable to any parameter and range; isolated from input and from ground. Not for use with externally powered circuits.
Serial output:	RS232, maximum distance of 50 feet (15 m); RS422, maximum distance of 4000 feet (1220 m); field selectable up to 19.2 kbaud. External isolation required with 50 $\text{cm}^{-1}$ sensor.

## Performance

Accuracy:	$\pm 0.5\%$ of reading or $\pm 0.5$ ohm, whichever is greater; $\pm 0.25$ $^\circ\text{C}$ (3-wire measurement)
Repeatability:	$\pm 0.1\%$ of reading, $\pm 0.13$ $^\circ\text{C}$
Update Rate:	All measurements and outputs, once per second
Ratings/approvals:	Meets CSA/NRTL and CE requirements, UL listed
Analog output accuracy:	$\pm 0.05$ mA within 15-30 $^\circ\text{C}$ ambient

## Environmental

Storage temperature:	-40 to 70 $^\circ\text{C}$ (-40 to 158 $^\circ\text{F}$ )
Operating temperature:	-10 to 55 $^\circ\text{C}$ (14 to 13 $^\circ\text{F}$ )
Humidity:	0 to 95% RH, non-condensing
General:	If the equipment is used in a manner not specified by Thornton, the protection provided by the equipment may be impaired. For indoor use, pollution degree 1.
UL Electrical Environment:	Installation (overvoltage) Category II

## Enclosure

Display:	16 character backlit LCD (4.8 x 9.6 mm)
Keypad:	11 flush, tactile feedback keys
Material:	ABS-PC polymer alloy
Panel cutout:	3.78 x 7.56" (96 x 192 mm) DIN
Wall mount:	Available with accessory back cover
Pipe mount:	For 1-1/2 to 4" vertical pipe, available with accessory kit and back cover
Weight:	1.9 lb. (0.9 kg)
Rating:	NEMA 4X, IP65 panel mount and accessory back cover
Sensor cable length, max:	200 feet (61 m)

## Power

Line:	90-130 VAC or 180-250 VAC, 50-60 Hz, 12W maximum; or 12-30 VDC, 300 mA steady state, 600 mA inrush. DC power must be isolated from earth ground.
Memory retention:	On power loss all programmed values are retained in non-volatile memory without batteries.

## 200CR Instrument Models

Relays	Analog Outputs	Power	Part No.
2 SPDT mechanical	0	110VAC (24 VDC)	6220-1
2 SPDT mechanical	0	220VAC (24 VDC)	6220-2
2 SPDT mechanical	2	110VAC (24 VDC)	6222-1
2 SPDT mechanical	2	220VAC (24 VDC)	6222-2
2 SPDT mechanical & 2 solid state, AC only	2	110VAC (24 VDC)	6242-1
2 SPDT mechanical & 2 solid state, AC only	2	220VAC (24 VDC)	6242-2

200CR operates as a 4-wire transmitter with either AC or DC power.  
24 VDC power must be isolated from earth ground and other instruments.

## Accessories

Description	Part No.
Wall Mount NEMA 4X, IP65 Back Cover	1000-62
Pipe Mount Bracket (1-1/2 to 4" vertical pipe)*	1000-63
Adapter plate, 800 Series to 200 Series	1000-64

\* Requires back cover above.

## Conductivity Flow Chambers

Description	Part No.
316 stainless steel, 1/8" NPTF inlet/outlet, 3/4" NPTF sensor port	1000-30
PVDF, 1/4" NPTF inlet/outlet, 3/4" NPTF sensor port	1000-31

## Retractable Housings for 240-212 Sensor

Material	Connection	Pressure	Temp	Part No.
CPVC	1 1/2" NPTM	75 psig (5 bar)	176°F (80°C)	1000-40
PVDF	1 1/2" NPTM	75 psig (5 bar)	212°F (100°C)	1000-41
316SS	1" NPTM	100 psig (7 bar)	248°F (120°C)	1000-42

## Sensor Patch Cords

Length	Standard Part No.	VP* Part No.
1 ft (0.3 m)	1001-66	-
5 ft (1.5 m)	1005-66	58 080 201
10 ft (3 m)	1010-66	58 080 202
15 ft (4.5 m)	1015-66	58 080 203
25 ft (7.6 m)	1025-66	58 080 204
50 ft (15.2 m)	1050-66	58 080 205
75 ft (23 m)	-	58 080 206
100 ft (30.5 m)	1110-66	58 080 207
150 ft (45.7 m)	1115-66	58 080 208
200 ft (61 m)	1120-66	58 080 209

One cord is required for each sensor except 240-217, -218, -220

\* For VP Conductivity sensors only. See sensor table, third column.

200CR Plug-in Calibrators - NIST Traceable,  $\pm 0.08\%$  Accuracy

Description	Part No.		
Complete Kit (Contains calibrators 1864-01, -02, -03, -04)	1865-03		
High Resistivity/Low Conductivity Kit (includes 1864-01, -02)	1865-01		
<b>Cal. Resistance</b>	<b>Cal. Point (0.1 cm<sup>1</sup> cell)</b>	<b>Temp.</b>	<b>Calibrator</b>
4 M $\Omega$	40 M $\Omega$ -cm	104°C	1864-01
100,000 $\Omega$	1 M $\Omega$ -cm	0°C	1864-02
Low Resistivity/High Conductivity Kit (includes 1864-03, -04)	1865-02		
<b>Cal. Resistance</b>	<b>Cal. Point (0.1 cm<sup>1</sup> cell)</b>	<b>Temp.</b>	<b>Calibrator</b>
20,000 $\Omega$	200,000 $\Omega$ -cm	104°C	1864-03
1,000 $\Omega$	10,000 $\Omega$ -cm	0°C	1864-04
<b>Cal. Resistance</b>	<b>Cal. Point (0.1 cm<sup>1</sup> cell)</b>	<b>Temp.</b>	<b>UPW Calibrator</b>
1.818 M $\Omega$	18.18 M $\Omega$ -cm	25°C	1865-04

Adapter, VP to Standard connector for calibrating a channel with VP patch cord - 58 080 102.



240-212 & 1000-41      240-201 & 1000-30      243E223      240-401      240-501      240-202      240-201      243E233



1XXX-66 Std. Patch Cord



58 080 20X VP Patch Cord



1865-0X Calibrator Kit



58 080 102 VP Calibrator Adapter

**200CR Application and Sensor Ranges**

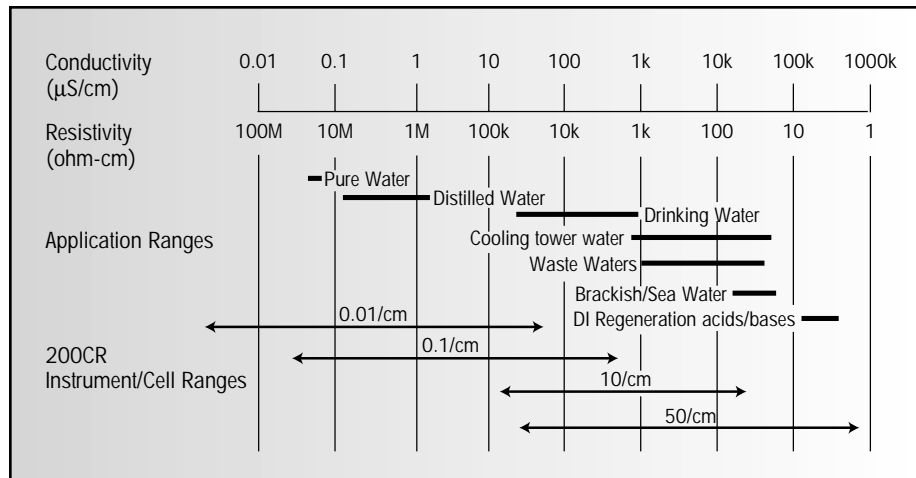

## Sensor Selection Criteria

- Conductivity or resistivity range — resistivity (Mohm-cm) = 1/conductivity (µS/cm)
- Mounting type — Insertion, retractable or submersion
- Pipe connection type and size
- Chemical compatibility, including cleaning and disinfection processes. Rely on process experience or consult Thornton for unusual process composition. PEEK is recommended for exposure to ozone and other oxidizers. Monel is recommended for exposure to hydrofluoric acid.
- Temperature requirements, including steam and/or hot chemical cleaning
- Suspended solids — four-electrode sensors have flat surfaces which are less likely to accumulate solids and are easier to clean than others. See the Thornton 2000 system data sheet for these applications.

## Specifications

<b>Cell Constant Accuracy:</b>	± 1% of reading (± 5% for 240-401)
<b>Cell Constant Repeatability:</b>	± 0.25% (± 2% for 240-401)
<b>Temperature Sensor:</b>	Pt1000 RTD, (thermistor for 240-501)
<b>Temperature Accuracy:</b>	± 0.1°C at 25°C, except 240-501
<b>Cable Jacket Material:</b>	240-Series - PVC, 80°C rating; 243-Series - Teflon, 200°C rating
<b>Maximum Sensor Distance:</b>	200 ft (61 m)
<b>Surface Finish (sanitary sensor):</b>	Ra 8 microinches (0.2 micrometers), 316L SS is electropolished

Fitting	Insertion Length "X" in (mm)	Cable Length ft (m)/ Connector	Fitting Material	Range (µS/cm)*	Cell Const. (cm-1)	Electrode Material	Insulator Material	Max Pressure/Temp Psig (bar) at °F (°C)	Part No.
3/4" NPTM	1.35 (34)	1.5 (0.5)/S	Teflon/SS	0.02-600	0.1	Titanium	PEEK	250 (17) at 200 (93)	240-201
3/4" NPTM	5.19 (132)	1.5 (0.5)/S	Teflon/SS	0.02-600	0.1	Titanium	Ryton	250 (17) at 200 (93)	240-202
3/4" NPTM	1.35 (34)	1.5 (0.5)/S	Teflon/SS	0.02-600	0.1	Monel	PEEK	250 (17) at 200 (93)	240-203
3/4" NPTM	5.19 (132)	1.5 (0.5)/S	Teflon/SS	0.02-600	0.1	Monel	Ryton	250 (17) at 200 (93)	240-204
3/4" NPTM	5.19 (132)	1.5 (0.5)/S	Teflon/SS	0.02-600	0.1	Titanium	PEEK	250 (17) at 200 (93)	240-206
3/4" NPTM***	1.15 (29)	None/S	PVDF	0.02-600	0.1	Titanium	PEEK	100 (7) at 203 (95) & 500 (34) at 77 (25)	240-207
Retractable for 1000-4X housing	2.75 (70)	None/S	SS	0.02-200	0.1	316L SS	PEEK	58 (4) at 268 (131) & 100 (7) at 203 (95) & 250 (17) at 77 (25)	240-212
1/2" NPTM	1.14 (29)	1.5 (0.5)/S	Noryl	0.02-600	0.1	Titanium	PEEK	250 (17) at 200 (93)	240-213
3/4" NPTM	1.14 (29)	1.5 (0.5)/S	Noryl	0.02-600	0.1	Titanium	PEEK	250 (17) at 200 (93)	240-214
3/4" NPTM	1.35 (34)	10 (3)/S	Teflon/SS	0.02-600	0.1	Titanium	PEEK	250 (17) at 200 (93)	240-215
1/2" NPTM	1.14 (29)	1.5 (0.5)/S	Teflon/SS	0.02-600	0.1	Titanium	PEEK	250 (17) at 200 (93)	240-216
3/4" NPTM	1.35 (34)	20 (6.1)**	Teflon/SS	0.02-600	0.1	Titanium	PEEK	250 (17) at 200 (93)	240-217
1/2" NPTM	1.14 (29)	10 (3)**	Teflon/SS	0.02-600	0.1	Titanium	PEEK	250 (17) at 200 (93)	240-218
3/4" NPTM	1.35 (34)	30 (9)**	Teflon/SS	0.02-600	0.1	Titanium	PEEK	250 (17) at 200 (93)	240-220
3/4" NPTM	2.38 (60)	1.5 (0.5)/S	Teflon/SS	0.002-100	0.01	Titanium	PEEK	250 (17) at 200 (93)	240-101
1.5" Tri-Clamp	3.38 (86)	1.5 (0.5)/S	Titanium	0.02-600	0.1	Titanium	PEEK	150 (10) at 311 (155) &	243E221†
1.5" Tri-Clamp	3.38 (86)	1.5 (0.5)/S	316L SS	0.02-600	0.1	316L SS	PEEK	450 (31) at 77 (25)	243E223†
2.0" Tri-Clamp	4.13 (105)	1.5 (0.5)/S	316L SS	0.02-600	0.1	316L SS	PEEK		243E227†
3/4" NPTM	3.38 (86)	1.5 (0.5)/S	Teflon/SS	10-40,000	10	Graphite	Noryl	250 (17) at 200 (93)	240-401
1" NPTM	4.90 (125)	1.5 (0.5)/S	PVDF/	20-1,000K	50	Graphite	Epoxy	100 (7) at 200 (93)	240-501††
3/4" NPTM	1.35 (34)	1.5 (0.5)/VP	Teflon/SS	0.02-600	0.1	Titanium	PEEK	250 (17) at 200 (93)	240-231
3/4" NPTM	5.19 (132)	1.5 (0.5)/VP	Teflon/SS	0.02-600	0.1	Titanium	PEEK	250 (17) at 200 (93)	240-236
1.5" Tri-Clamp	3.35 (85)	None/VP	316L SS	0.02-600	0.1	316L SS	PEEK	150 (10) at 311 (155) &	243E233†
2.0" Tri-Clamp	4.10 (104)	None/VP	316L SS	0.02-600	0.1	316L SS	PEEK	450 (31) at 77 (25)	243E237†

All 0.01 and 0.1 cm<sup>1</sup> Sensors include calibration certificates. Others may be requested at additional cost.

\* Megohm-cm = 1/(µS/cm)

\*\* tinned leads, no patch cord required

\*\*\* plus 1" NPTM submersion connection

† includes material certification to meet EN10204 3.1B.

†† with a 50 constant sensor, the second channel must not be used.

S = Standard connector used with 1XXX-66 patch cords only.

VP = Vario Pin sealed connector used with 58 080 20X patch cords only, provides highest integrity connection. (58 080 101 3-ft. adapter cable can connect an existing 1XXX-66 patch cord to a VP sensor.)

**NPT 0.01 and 0.1 Constant**

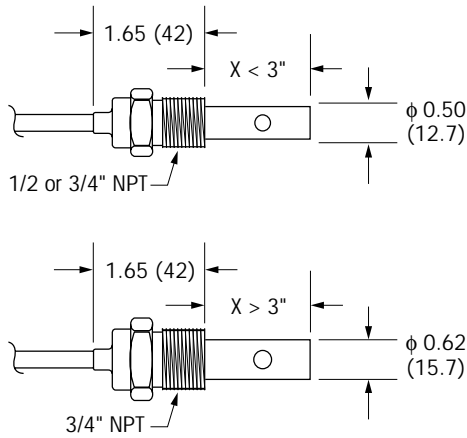

**10 Constant 240-401**

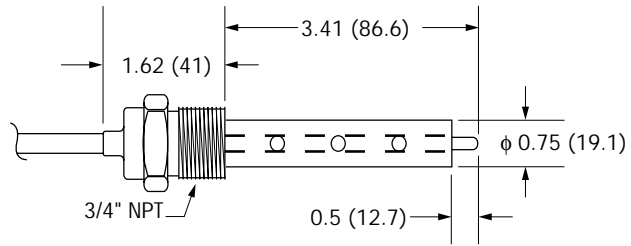

**50 Constant 240-501**

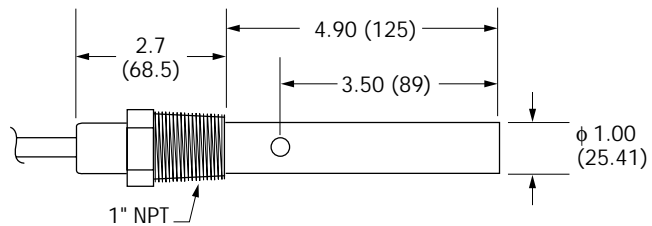

**Sanitary 243E22X**

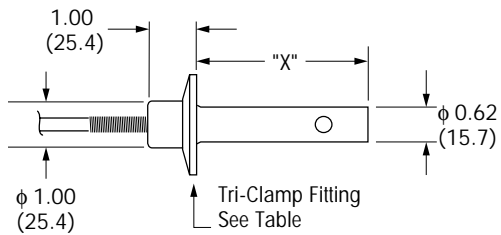

**Submersion 0.1 Constant 240-207**

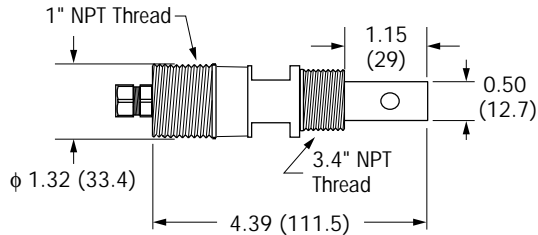

**316SS Flow Chamber 1000-30**

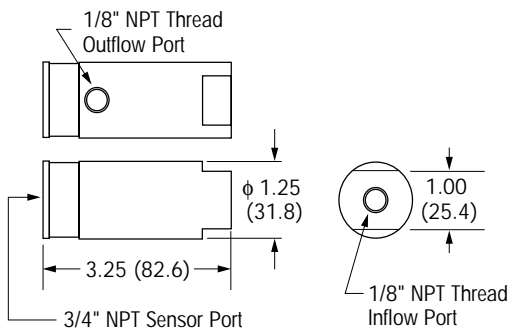

**PVDF Flow Chamber 1000-31**

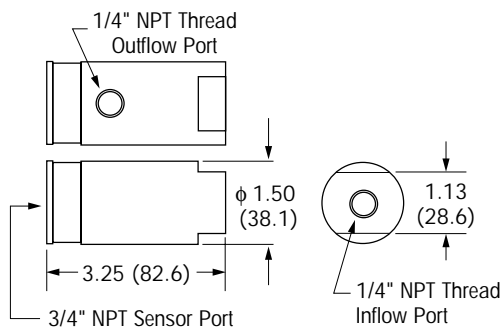

**240-212 Sensor and 1000-4x Retractable Housing**

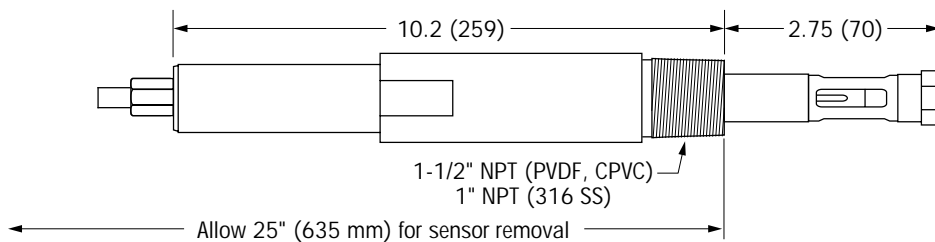

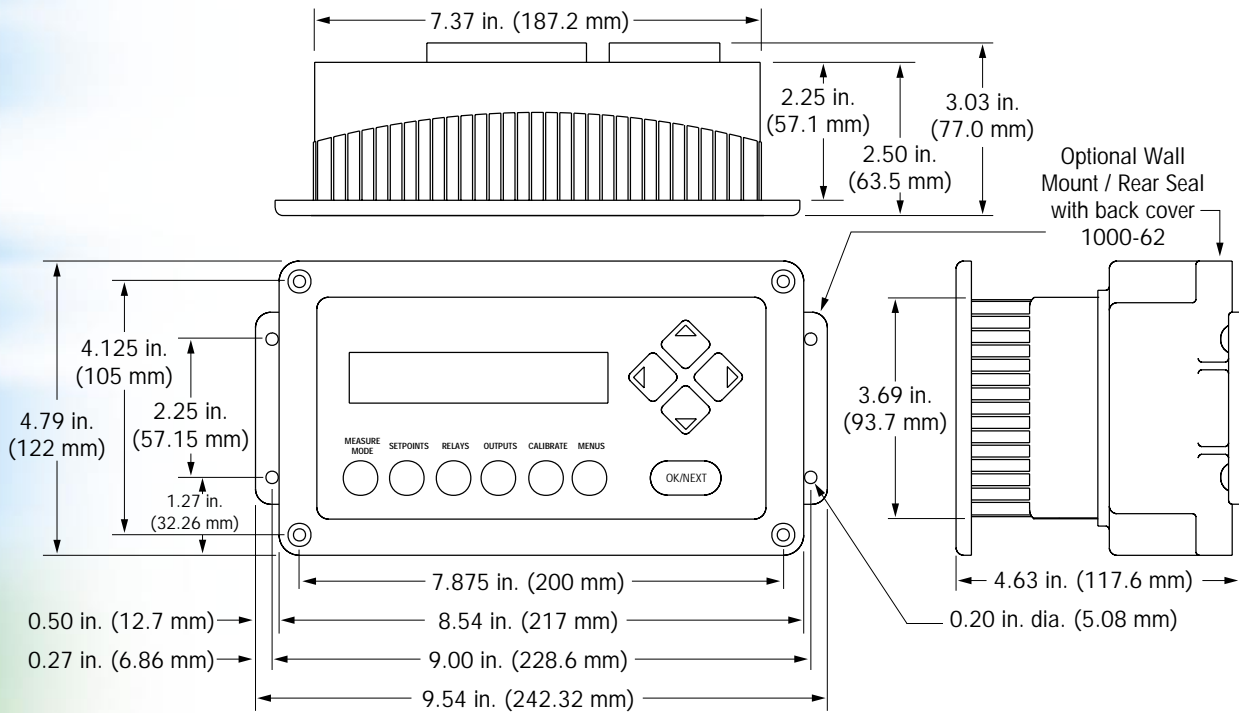

For the most current product information visit:  
[www.thorntoninc.com](http://www.thorntoninc.com)

Mettler-Toledo Thornton, Inc.  
 36 Middlesex Turnpike  
 Bedford, MA 01730 USA  
 Telephone: +1-781-301-8600  
 Toll-Free: 1-800-510-PURE

Customer/Technical Service  
 Telephone: +1-781-301-8690  
 Toll-Free: 1-800-642-4418  
 Cust Service Fax: +1-781-271-0214  
 Tech Service Fax: +1-781-271-0675

email: [info@thorntoninc.com](mailto:info@thorntoninc.com)  
[www.thorntoninc.com](http://www.thorntoninc.com)

ML0026 Rev.K 09/03