

GMT220 Series Carbon Dioxide Transmitters for Harsh and Humid Industrial Applications



Vaisala CARBOCAP® Carbon Dioxide Transmitter Series GMT220 withstand harsh and humid environments.

The Vaisala CARBOCAP® Carbon Dioxide Transmitter Series GMT220 is designed to measure carbon dioxide in harsh and humid environments. The housing is dust and waterproof to IP65 (NEMA 4) standards. The materials have been chosen for good corrosion resistance.

High-end measurement technology

The GMT220 series incorporate the advanced Vaisala CARBOCAP® Sensor. The patented sensor has unique reference measurement capabilities. Its critical parts are made of silicon; this gives the sensor outstanding stability over both time and temperature. By lengthening the time between calibration intervals, the user saves both time and money.

Optimal measurement range for each application

The user has a choice of measurement ranges up to 20 % CO₂; the GMT221 for higher concentrations of CO₂ and the

GMT222 for lower concentrations of CO₂. The transmitter can be connected to various measurement systems. In addition to standard analog, voltage and current outputs, there are also two configurable alarm relay outputs. Activated relays are indicated by LED lights on the cover. An optional LonWorks® digital interface is also available.

Interchangeable probes

The GMT220 probes are truly interchangeable. They can be removed and reattached or replaced at any time – without the need for calibration and adjustment. The probes can be attached directly to the transmitter body or, when used with a cable, installed remotely into hard-to-reach places or areas with dangerously high levels of CO₂.

Simple installation

A separate mounting plate makes installing the transmitter easy - simply attach the mounting plate to the wall and lock the transmitter body in place.

Features/Benefits

- Incorporates Vaisala CARBOCAP® Sensor - the silicon-based NDIR sensor
- IP65 (NEMA 4) protected against dust and spray water
- Choice of several measurement ranges
- Easy installation
- Interchangeable probes – easy maintenance

Applications

- Horticulture and fruit storage
- Greenhouses and mushroom farming
- Safety alarming and leakage monitoring
- Demand controlled ventilation in harsh environments

Easy field maintenance

Since the probes of the GMT220 transmitters are truly interchangeable, they facilitate easy field maintenance.

The probes can either be replaced with newly calibrated probes or with separate probes that are only used as a reference for calibration checking. This minimizes downtime. The end user can do field maintenance without any additional equipment or heavy and expensive calibration gas bottles. Any replaced probes can be sent to Vaisala for recalibration.

The Vaisala CARBOCAP® Hand-Held Carbon Dioxide Meter GM70 is ideal for field verification and/or calibration.



Technical Data

General

Measurement Ranges	
GMT221	0...2% CO ₂ 0...3% CO ₂ 0...5% CO ₂ 0...10% CO ₂ 0...20% CO ₂
GMT222 for low concentrations	0...2000 ppm 0...3000 ppm 0...5000 ppm 0...7000 ppm 0...10 000 ppm
Accuracy at +25 °C (+77 °F) against certified factory references	
GMT221	<±[0.02% CO ₂ + 2% of reading]
GMT222	<±[20 ppm CO ₂ + 2% of reading] (incl. repeatability and calibration uncertainty)
Nonlinearity	<±1.0 %FS
Temperature dependence of output (typical value)	0.1 %FS /°C (±0.05 %FS /°F)
Pressure dependence (typ.)	0.15% of reading/hPa
Long-term stability	<±5 %FS/2 years
Response time (63%)	
GMT221	20 seconds
GMT222	30 seconds

GMT221/222

Analog output signals	0...20 or 4...20 mA and 0...10 V
Resolution of analog outputs	0.03 %FS
Recommended external load:	
current output	max. 400 Ohm
voltage output	min. 1 kOhm
Two pre- or user-defined relay outputs	
Relay contacts	max. 30VAC/60VDC, 0.5A
Power supply	nominal 24 VAC/DC
Power consumption	<4 W
Warm-up time	30 seconds
	15 minutes full specifications
Operating temperature range	-20...+60 °C (-4...+140 °F)
display	0...+50 °C (+32...+122 °F)
Storage temperature range	-30...+70 °C (-22...+158 °F)
Operating humidity range	0...100 %RH non-condensing
Housing material	
transmitter body	ABS plastic
probe	PC plastic
Housing classification	IP65 (NEMA 4)
Weight:	
GMT221	max. 280 g
GMT222	max. 300 g
Probe cable length	2 m and 10 m (optional)

Accessories

GMP221, GMP222	spare probe
(use the order form to define measurement range etc.)	
25245GM	clips (2 pcs) for attaching the probe
GM45156	mounting flange for the probe
25665GMSP	2.0 m probe cable
210848GMSP	10.0 m probe cable

GMK220	calibration kit for interchangeable probes
19040GM	serial COM adapter for maintenance purposes
26150GM	chamber for pump aspirated sampling systems
GM70	Hand-held CO ₂ meter for field verification and calibration

Electromagnetic compatibility

Complies with EMC standard EN61326-1:1997 + Am1:1998 + Am2:2001; Generic Environment.

Dimensions

Dimensions in mm (inches)

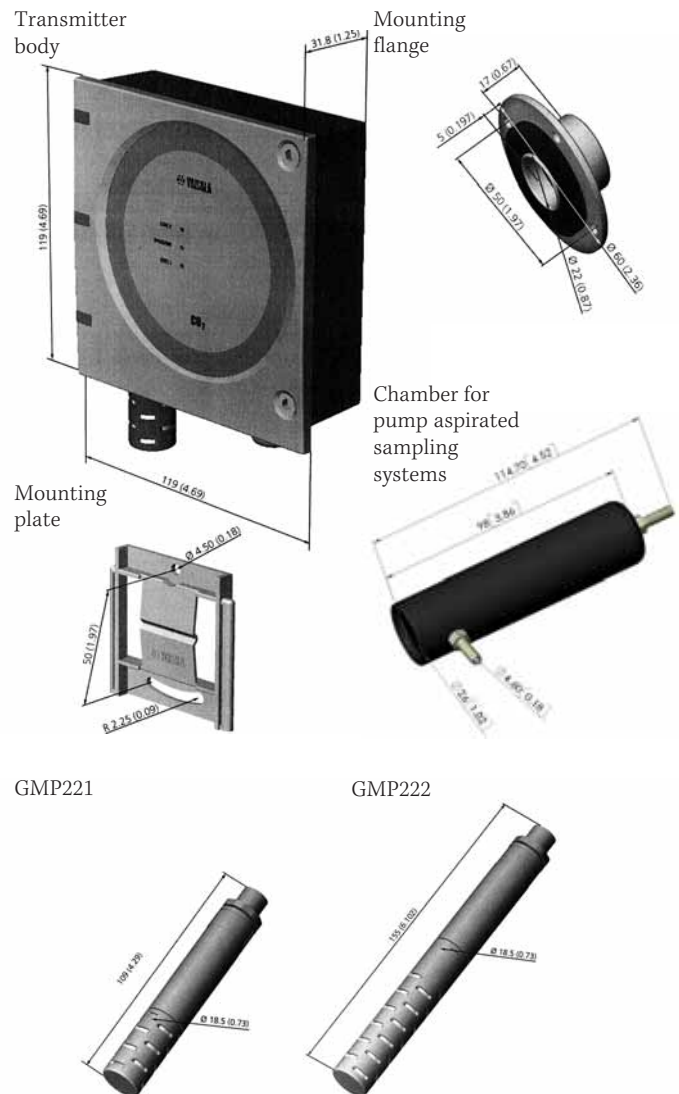

CARBONCAP® is a registered trademark of Vaisala.
Specifications subject to change without prior notice.
©Vaisala Oyj

