

HM70 Hand-Held Humidity and Temperature Meter for Spot-Checking Applications



The Vaisala HUMICAP® Hand-Held Humidity and Temperature Meter HM70 is a high-performance, portable humidity reference that is exciting to use.

The Vaisala HUMICAP® Hand-Held Humidity and Temperature Meter HM70 is a user-friendly meter for demanding spot-checking humidity measurements. It is ideal for field checking and calibration of Vaisala's fixed humidity instruments.

Three probes to choose from

The HMP75 is a general purpose probe for humidity measurements between -20 and +60 °C. The HMP76 is a long, stainless steel probe for humidity measurements between -50 and +120 °C. It is especially suitable for spot-checking in ducts. The HMP77 probe has a small sensor head at the end of a 5-meter cable. The probe is ideal for difficult-to-reach areas and for on-site calibration of Vaisala's process transmitters. The measurement range is for temperatures up to +180 °C.

One or two probes can be connected simultaneously. In addition, the HM70 supports the use of Vaisala's dewpoint, carbon dioxide and moisture in oil probes, allowing measurements in multiparameter applications.

Easy-to-use user interface and three-variable display

The HM70 features a multilingual, menu-based user interface, and a clear graphical LCD display. Overall three measurement parameters can be displayed and logged into the meter's memory at the same time. An analog output option is also available.

Proven HUMICAP® technology

The HM70 incorporates Vaisala HUMICAP® Sensor, which provides reliable and high performance humidity measurement with excellent long-term stability.

Options improve performance in demanding applications

The chemical purge option maintains measurement accuracy in environments with high concentrations of chemicals. The sensor preheat option reduces measurement delays by keeping the sensor dry when the probe is inserted into hot and humid processes.

Features/Benefits

- Multilingual user interface
- Shows measurement trends graphically
- Proven Vaisala HUMICAP® Sensor technology
- 3 probes, temperature measurement ranges between -70 and +180 °C
- Multiprobe operation; dewpoint and CO₂ probes can also be connected
- Displays various humidity parameters
- Sensor preheat and chemical purge options for demanding conditions
- Data can be logged, and transferred to a PC via MI70 Link software
- Rugged and reliable - even in extreme conditions
- NIST traceable (certificate included)

Order Guide: Page 163

Calibration

The meter is calibrated at the factory against traceable standards, and delivered with a calibration certificate. Also, the HM70 is available with accredited calibration.

The HM70 probes can be sent to a Vaisala Service Center for a traceable recalibration.

MI70 Link

The optional MI70 Link Windows® software is a practical tool for transferring logged data and real time measurement data from the HM70 to a PC.

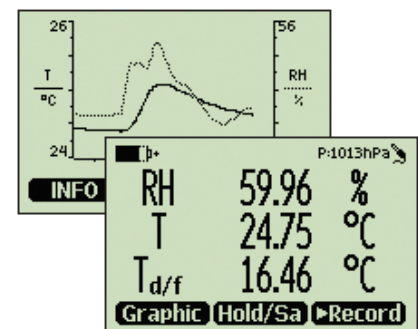

The graphic display shows the stabilization of measurements and process trends.

Technical Data

HMP75, HMP76 and HMP77 probes

Measured variables

Relative humidity

Measurement range	0...100 %RH
Accuracy (including nonlinearity, hysteresis and repeatability)	
at +20 °C (+68 °F)	±1 %RH (0...90 %RH)
	±1.7 %RH (90...100 %RH)
at -20...+40 °C (-4...+104 °F)	±(1.0 + 0.008 x reading) %RH
at -40...-20 °C (-40...-4 °F)	
at +40...+180 °C (+104...+356 °F)	±(1.5 + 0.015 x reading) %RH
Factory calibration uncertainty (+20 °C / +68 °F)	
	±0.6 %RH (0...40 %RH)
	±1.0 %RH (40...97 %RH)
	(Defined as ±2 standard deviation limits.)

Response time (90%) at +20 °C (+68 °F) still air

HMP75 (with standard plastic grid)	8 s
HMP76 (with standard sintered bronze filter)	40 s
HMP77 (with standard plastic grid with stainless steel netting)	20 s

Sensor HUMICAP® 180C (chemical purge, sensor preheat)

Typical long-term stability better than 1 %RH / year

Temperature

Measurement range	
HMP75	-20...+60 °C (-4...+140 °F)
HMP76	-50...+120 °C (-58...+248 °F)
short time	-50...+180 °C (-58...+356 °F)
HMP77	-70...+180 °C (-94...+356 °F)
Accuracy at +20 °C (+68 °F)	±0.2 °C (0.36 °F)
Accuracy over temperature range (see graph).	

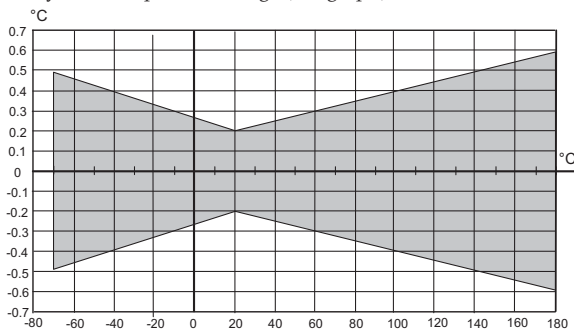

Temperature sensor Pt100 IEC751 1/3 class B

Calculated variables (typical ranges)

Dewpoint temperature	-20...+100 °C (-4...+212 °F)
Mixing ratio	0...600 g/kg dry air
Absolute humidity	0...600 g/m ³
Wet bulb temperature	0...100 °C (+32...+212 °F)
Enthalpy	0...160 kJ/g
Water vapor pressure	0...1000 hPa

The accuracies of these calculated variables are limited by the accuracies of the measured variables on which they are based, namely RH and T. The RH and T accuracies are stated above under Measured Variables.

Probe general

Operating temperature range for electronics	-40...+60 °C (-40...+140 °F)
Housing classification	IP65 (NEMA 4)
Housing material	ABS/PC blend
Probe material	Stainless steel (AISI316L)
Cable length between probe and indicator	1.9 m
Weight	
HMP75	250 g
HMP76	350 g
HMP77	500 g

MI70 measurement indicator

Indicator general

Menu languages	English, French, Spanish, German, Swedish, Finnish
Display	LCD with backlight, graphic trend display of any parameter, character height up to 16 mm
Probe inputs	1 or 2
Power supply	Rechargeable NiMH battery pack with AC-POWER or 4xAA-size alkalines, type IEC LR6
Analog output	0...1 VDC
Output resolution	0.6 mV
Data interface	RS-232
Data logging capacity	2700 points
Alarm	audible alarm function
Operating temperature range	-10...+40 °C (+14...+104 °F)
Operating humidity range	non-condensing
Housing classification	IP54
Weight	400 g
Battery operation time	
Continuous use	48 h typical at +20 °C (+68 °F)
Datalogging use	up to 30 days
Complies with EMC standard	EN61326-1:1997 + Am1:1998 + Am2:2001; Industrial Environment.

MI70 indicator + probe = HM70

Accessories

Carrying cases	
for MI70 and HMP75/77 probe	MI70CASE
for MI70 and HMP75/76 probe	MI70CASE2
Transmitter connection cables for	
HMP230 Series	27159ZZ
HMT330 & HMT320 Series	211339
HM60/70/140 Series	HMA6070
HM20/30/130 Series	HMA2030
Analog output cable	27168ZZ
Windows' software, includes PC connection cable	MI70LINK
Sensor protection	
HMP75	
Plastic PC grid (HMP75 standard)	6221
Membrane filter	10159HM
Sintered bronze filter	DRW212987SP
HMP76/77	
Plastic PPS grid	DRW010276SP
Sintered stainless steel filter	HM47280SP
Sintered bronze filter (HMP76 standard)	DRW212987SP
PPS grid with SS netting (HMP77 standard)	DRW010281SP

Dimensions

Dimensions in mm (inch)

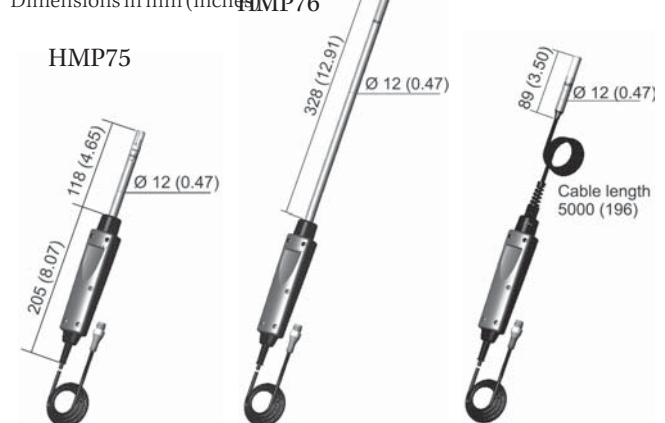

HUMICAP® is a registered trademark of Vaisala.
Specifications subject to change without prior notice.
© Vaisala Oyj

